

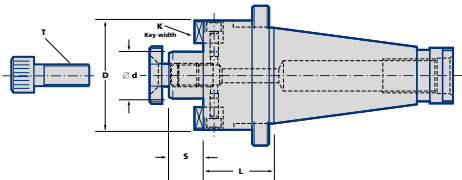

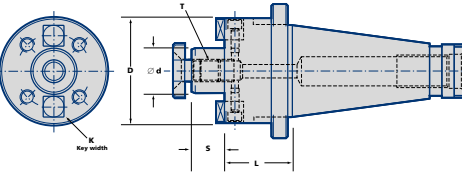
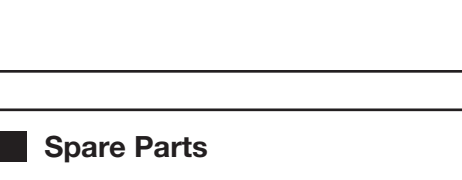

Face Mill/Shell Mill Adaptors

Fig 1		Taper	Ordering No.	Stock	Fig.	d	L	S	D	K	T
 <p>SM16 and SM22 supplied with Caphead Screw</p>	30	QC30-SM16-040	○	1	16	40	17	44	8	M8	
		QC30-SM22-040	●	1	22	40	19	44	10	M10	
		QC30-SM27-040	●	1	27	40	21	50	12	M12	
		QC30-SM32-043	○	1	32	43	24	78	14	M16	
	40	QC40-SM16-030	○	1	16	30	17	44	8	M8	
		QC40-SM22-036	●	1	22	36	19	50	10	M10	
		QC40-SM27-036	●	1	27	36	21	50	12	M12	
		QC40-SM32-042	●	1	32	42	24	78	14	M16	
		QC40-SM40-043	●	2	40	43	26	89	16	M20	
	50	DT50-SM22-050	●	1	22	50	19	50	10	M10	
		DT50-SM27-050	○	1	27	50	21	60	12	M12	
		DT50-SM32-050	●	1	32	50	24	78	14	M16	
		DT50-SM40-055	●	2	40	55	26	89	16	M20	
		DT50-SM60-060	●	2	60	60	25	129	25,4	-	
Spare Parts	Wrenches		Retaining Screws		Drivekeys						
		See page 131		See page 140		See page 140					

● = Standard Product - Normally Ex Stock
○ = Standard Product - Availability on Request

Packing unit and ordering example: 1 piece QC30-SM16-040