

Quick Change Tap Adaptors: Fixed Length - Code RC

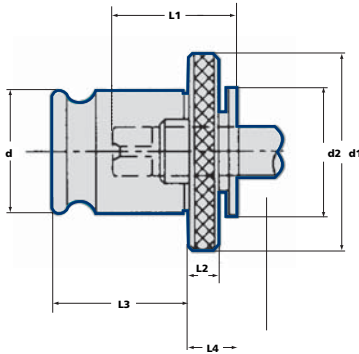

Collet Series	Tap capacity ISO-STD	Stock	d	d1	D2	L1	L2	L3	L4
RC0	M1-M8	•	13	22	13	15	4	19,5	7
RC1	M4-M14	•	19	30	19	17	4	21,5	7
RC2	M7-M24	•	31	48	30	30	5	35,0	11
RC3	M14-M42	•	48	70	48	44	6	55,5	14
RC4	M24-M48	○	60	92	60	71	13	63,0	42

Quick Change Tap Adaptors: Fixed Length - Code RC

Ordering No.	Shank dia	sqr a/f	ISO 529/1982					DIN				Range Prefix	
			metric	unc/unf	bsw/bsf	bsp	ba	352	371	374	376		
TA-025-020	2.50	2.00	M1/M2	0/1	1/16"	-	14.9	-	-	-	-		
TA-025-021	2.50	2.10	-	-	-	-	-	M1	M1	M3	-	RC0	
TA-028-021	2.80	2.10	-	-	-	-	-	M2	M2	-	M4		
TA-028-023	2.80	2.24	M2.5	2/3	3/32"	-	8.6	-	-	-	-		
TA-032-025	3.15	2.50	M3	4/5	1/8"	-	5	-	-	-	-		
TA-035-027	3.50	2.70	-	-	-	-	-	M3	M3	-	M5		
TA-036-028	3.55	2.80	M3.5	6	-	-	4	-	-	-	-		RC1
TA-040-032	4.00	3.15	M4	-	5/32"	-	-	-	-	-	-		
TA-045-034	4.50	3.40	-	-	-	-	-	M4	M4	M6	M6		
TA-045-036	4.50	3.55	M4.5	8	-	-	3	-	-	-	-		
TA-050-040	5.00	4.00	M5	10	3/16"	-	2	-	-	-	-		
TA-056-045	5.60	4.50	-	12	7/32"	-	1	-	-	-	-		
TA-060-049	6.00	4.90	-	-	-	-	-	M5,M6	M5,M6	-	-		
TA-060-049	-	-	-	-	-	-	-	M8	-	-	M8		
TA-063-050	6.30	5.00	M6	1/4"	1/4"	-	0	-	-	-	-		
TA-070-055	7.00	5.50	-	-	-	-	-	M10	-	-	M10		
TA-071-056	7.10	5.60	M7	-	-	-	-	-	-	-	-		RC2
TA-080-063	8.00	6.30	M8	5/16"	5/16"	1/8"	-	-	M8	-	-		
TA-080-063	-	-	M11	7/16"	7/16"	-	-	M11	-	M11	M11		
TA-090-071	9.00	7.10	M9,M12	1/2"	1/2"	-	-	M12	M9	M12	M12		
TA-100-080	10.00	8.00	M10	3/8"	3/8"	1/4"	-	-	M10	-	-		

Please ensure that the Range Prefix code precedes the rest of the code number when ordering - e.g. RC2 TA-100-080

- = Standard Product - Normally Ex Stock
- = Standard Product - Availability on Request

Collets

Quick Change Tap Adaptors: Fixed Length - Code RC cont'd

Ordering No.	Shank dia	sqra/f	ISO 529/1982					DIN				Range Prefix			
			metric	unc/unf	bsw/bsf	bsp	ba	352	371	374	376				
TA- 110- 090	11.00	9.00	-	-	-	-	-	M14	-	M14	M14	RC3	RC2		
TA- 112- 090	11.20	9.00	M14	9/16"	9/16"	-	-	-	-	-	-				
TA- 120- 090	12.00	9.00	-	-	-	-	-	M16	-	M16	M16				
TA- 125- 100	12.50	10.00	M16	5/8"	5/8"	-	-	-	-	-	-				
TA- 125- 100BSP	-	-	-	-	-	3/8"	-	-	-	-	-				
TA- 140- 112	14.00	11.20	M18,M20	3/4"	3/4"	-	-	M18	-	M18	M18				
TA- 160- 120	16.00	12.00	-	-	-	-	-	M20	-	M20	M20				
TA- 160- 125	16.00	12.50	M22	7/8"	7/8"	-	-	-	-	-	-				
TA- 160- 125BSP	-	-	-	-	-	1/2"	-	-	-	-	-				
TA- 180- 140	18.00	14.00	M24	1"	1"	-	-	-	-	-	-			RC4	
TA- 180- 140BSP	-	-	-	-	-	5/8"	-	-	-	-	-				
TA- 180- 145	18.00	14.50	-	-	-	-	-	M22,M24	-	M22,M24	M22,M24				
TA- 200- 160	20.00	16.00	M27,M30	1.1/8"	1.1/8"	-	-	M27	-	M27	M27				
TA- 200- 160BSP	-	-	-	-	-	3/4"	-	-	-	-	-				
TA- 220- 180	22.00	18.00	-	-	-	-	-	M30	-	M30	M30				
TA- 220- 180BSP	-	-	-	-	-	7/8"	-	-	-	-	-				
TA- 224- 180	22.40	18.00	M33	1.1/4"	1.1/4"	-	-	-	-	-	-				
TA- 250- 200	25.00	20.00	M36	1.3/8"	1.3/8"	-	-	M33	-	M33	M33				
TA- 250- 200BSP	-	-	-	-	-	1"	-	-	-	-	-				
TA- 280- 220	28.00	22.00	-	-	-	-	-	M36	-	M36	M36				
TA- 280- 224	28.00	22.40	M39,M42	1.1/2"	1.1/2"	-	-	-	-	-	-				
TA- 280- 224BSP	-	-	-	-	-	1.1/8"	-	-	-	-	-				
TA- 315- 250	31.50	25.00	M45,M48	1.3/4"	1.3/4"	-	-	-	-	-	-				
TA- 315- 250BSP	-	-	-	-	-	1.1/4"	-	-	-	-	-				
TA- 320- 240	32.00	24.00	-	-	-	-	-	M39,M42	-	M39,M42	M39,M42				
TA- 355- 280BSP	35.50	28.00	-	-	-	1.1/2"	-	-	-	-	-				
TA- 360- 290	36.00	29.00	-	-	-	-	-	M45,M48	-	M45,M48	M45,M48				

Please ensure that the Range Prefix code precedes the rest of the code number when ordering - e.g. RC2 TA-110-090

• = Standard Product - Normally Ex Stock
 ○ = Standard Product - Availability on Request

■ Quick Change Tap Adaptors: Slipping Clutch - Code RS

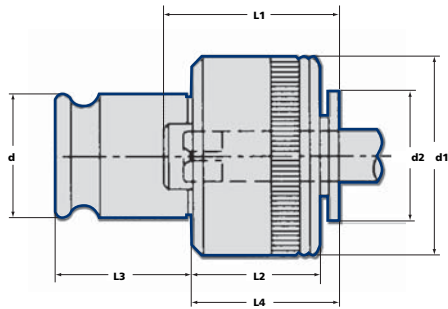

Collet Series	Tap capacity ISO-STD	Stock	d	d1	D2	L1	L2	L3	L4
RS0	M1-M8	•	13	23	13	15	20	19,5	21
RS1	M4-M14	•	19	32	19	17	25	21,5	25
RS2	M7-M24	•	31	50	30	30	31	35,0	34
RS3	M14-M42	○	48	72	48	48	41	55,5	45
RS4	M24-M48	○	60	95	60	60	61	63,0	68

Quick Change Tap Adaptors: Slipping Clutch - Code RS

Ordering No.	Shank dia	sqr a/f	ISO 529/1982					DIN				Torque set	Range Prefix
			metric	unc/unf	bsw/bsf	bsp	ba	352	371	374	376		
TA-025-020M010	2.50	2.00	M1/M2	0/1	1/16"	-	14.9	-	-	-	-	0.3	RSO
TA-025-021M010	2.50	2.10	-	-	-	-	-	M1	M1	-	-	0.3	
TA-025-021M030	-	-	-	-	-	-	-	-	-	M3	-	0.5	
TA-028-021M020	2.80	2.10	-	-	-	-	-	M2	M2	-	-	0.3	
TA-028-021M040	-	-	-	-	-	-	-	-	-	-	M4	1.2	
TA-028-022M025	2.80	2.24	M2.5	2/3	3/32"	-	8.6	-	-	-	-	0.4	
TA-032-025M030	3.15	2.50	M3	4/5	1/8"	-	5	-	-	-	-	0.5	
TA-035-027M030	3.50	2.70	-	-	-	-	-	M3	M3	-	-	0.5	
TA-035-027M050	-	-	-	-	-	-	-	-	-	-	M5	2.0	
TA-036-028M035	3.55	2.80	M3.5	6	-	-	4	-	-	-	-	0.8	
TA-040-032M040	4.00	3.15	M4	-	5/32"	-	-	-	-	-	-	1.2	
TA-045-034M040	4.50	3.40	-	-	-	-	-	M4	M4	-	-	1.2	
TA-045-034M060	-	-	-	-	-	-	-	-	-	M6	M6	4.0	
TA-045-036M045	4.50	3.55	M4.5	8	-	-	3	-	-	-	-	1.6	
TA-050-040M050	5.00	4.00	M5	10	5/16"	-	2	-	-	-	-	2.0	
TA-056-045MBSW	5.60	4.50	-	12	7/32"	-	1	-	-	-	-	2.5	
TA-060-049M050	6.00	4.90	-	-	-	-	-	M5	M5	-	-	2.0	
TA-060-049M060	-	-	-	-	-	-	-	M6	M6	-	-	4.0	
TA-060-049M080	-	-	-	-	-	-	-	M8	-	-	M8	8.0	
TA-063-050M060	6.30	5.00	M6	1/4"	1/4"	-	0	-	-	-	-	4.0	
TA-070-055M100	7.00	5.50	-	-	-	-	-	M10	-	-	M10	16	
TA-071-056M070	7.10	5.60	M7	-	-	-	-	-	-	-	-	6.0	
TA-080-063M080	8.00	6.30	M8	5/16"	5/16"	-	-	-	M8	-	-	8.0	
TA-080-063M110	-	-	M11	7/16"	7/16"	-	-	M11	-	M11	M11	19	
TA-080-063MBSP	-	-	-	-	-	1/8"	-	-	-	-	-	6.0	
TA-090-071M090	9.00	7.10	M9	-	-	-	-	-	M9	-	-	12	
TA-090-071M120	-	-	M12	1/2"	1/2"3/	-	-	M12	-	M12	M12	22	
TA-100-080M100	10.00	8.00	M10	3/8"	8"	-	-	-	-	-	-	16	
TA-355-280MBSP	-	-	-	-	-	1/4"	-	-	-	-	-	18	
TA-110-090M140	11.00	9.00	-	-	-	-	-	M14	-	M14	M14	36	
TA-110-090M140	11.20	9.00	M14	9/16"	9/16"	-	-	-	-	-	-	36	

Please ensure that the Range Prefix code precedes the rest of the code number when ordering - e.g. RSO-TA-025-020M010

• = Standard Product - Normally Ex Stock
 ○ = Standard Product - Availability on Request

Packing unit and ordering example: 1 piece RSO-TA025-020M010

Quick Change Tap Adaptors: Slipping Clutch - Code RS cont'd

Ordering No.	Shank dia	sqra/f	ISO 529/1982					DIN				Torque set	Range Prefix	
			metric	unc/unf	bsw/bsf	bsp	ba	352	371	374	376		RS3	RS2
TA-120-090M160	12.00	9.00	-	-	-	-	-	M16	-	M16	M16	40		
TA-125-100M160	12.50	10.00	M16	5/8"	5/8"	-	-	-	-	-	-	40	RS3	RS2
TA-110-090M140	-	-	-	-	-	3/8"	-	-	-	-	-	22		
TA-140-112M180	14.00	11.20	M18	-	-	-	-	M18	-	M18	M18	63		
TA-140-112M200	-	-	M20	3/4"	3/4"	-	-	-	-	-	-	70		
TA-160-120M200	16.00	12.00	-	-	-	-	-	M20	-	M20	M20	70		
TA-160-125M220	16.00	12.50	M22	7/8"	7/8"	-	-	-	-	-	-	80		
TA-160-125MBSP	-	-	-	-	-	1/2"	-	-	-	-	-	50		
TA-180-140M240	18.00	14.00	M24	1"	1"	-	-	-	-	-	-	125		
TA-180-140MBSP	-	-	-	-	-	5/8"	-	-	-	-	-	56		
TA-180-145M220	18.00	14.50	-	-	-	-	-	M22	-	M22	M22	80	RS4	
TA-180-145M240	-	-	-	-	-	-	-	M24	-	M24	M24	125		
TA-200-160M270	20.00	16.00	M27	-	-	-	-	M27	-	M27	M27	140		
TA-200-160M300	-	-	M30	1.1/8"	1.1/8"	-	-	-	-	-	-	220		
TA-200-160MBSP	-	-	-	-	-	3/4"	-	-	-	-	-	70		
TA-220-180M300	22.00	18.00	-	-	-	-	-	M30	-	M30	M30	220		
TA-220-180MBSP	-	-	-	-	-	7/8"	-	-	-	-	-	80		
TA-224-180M330	22.40	18.00	M33	1.1/4"	1.1/4"	-	-	-	-	-	-	240		
TA-250-200M360	25.00	20.00	M36	1.3/8"	1.3/8"	-	-	-	-	-	-	280		
TA-250-200M330	-	-	-	-	-	-	-	M33	-	M33	M33	240		
TA-250-200BSP	-	-	-	-	-	1"	-	-	-	-	-	140		
TA-280-220M360	28.00	22.00	-	-	-	-	-	M36	-	M36	M36	280		
TA-280-224M390	28.00	22.40	M39	1.1/2"	1.1/2"	-	-	-	-	-	-	320		
TA-280-224M420	-	-	M42	-	-	-	-	-	-	-	-	420		
TA-280-224BSP	-	-	-	-	-	1.1/8"	-	-	-	-	-	160		
TA-315-250M450	31.50	25.00	M45	1.3/4"	1.3/4"	-	-	-	-	-	-	480		
TA-315-250M480	-	-	M48	-	-	-	-	-	-	-	-	630		
TA-315-250BSP	-	-	-	-	-	1.1/4"	-	-	-	-	-	180		
TA-320-240M390	32.00	24.00	-	-	-	-	-	M39	-	M39	M39	320		
TA-320-240M420	-	-	-	-	-	-	-	M42	-	M42	M42	420		
TA-355-280BSP	35.50	28.00	-	-	-	1.1/2"	-	-	-	-	-	220		
TA-360-290M450	36.00	29.00	-	-	-	-	-	M45	-	M45	M45	480		
TA-360-290M480	-	-	-	-	-	-	-	M48	-	M48	M48	630		

• = Standard Product - Normally Ex Stock
 ○ = Standard Product - Availability on Request

Packing unit and ordering example: 1 piece RS3TA-100-080M100