

Quick Change Tap Adaptors: Fixed Length - Code RC

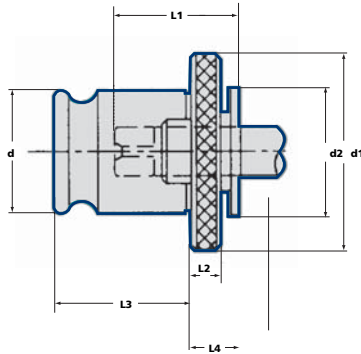

Collet Series	Tap capacity ISO-STD	Stock	d	d1	D2	L1	L2	L3	L4
RC0	M1-M8	•	13	22	13	15	4	19,5	7
RC1	M4-M14	•	19	30	19	17	4	21,5	7
RC2	M7-M24	•	31	48	30	30	5	35,0	11
RC3	M14-M42	•	48	70	48	44	6	55,5	14
RC4	M24-M48	○	60	92	60	71	13	63,0	42

Quick Change Tap Adaptors: Fixed Length - Code RC

Ordering No.	Shank dia	sqr a/f	ISO 529/1982					DIN				Range Prefix
			metric	unc/unf	bsw/bsf	bsp	ba	352	371	374	376	
TA-025-020	2.50	2.00	M1/M2	0/1	1/16"	-	14.9	-	-	-	-	RC0
TA-025-021	2.50	2.10	-	-	-	-	-	M1	M1	M3	-	
TA-028-021	2.80	2.10	-	-	-	-	-	M2	M2	-	M4	
TA-028-023	2.80	2.24	M2.5	2/3	3/32"	-	8.6	-	-	-	-	
TA-032-025	3.15	2.50	M3	4/5	1/8"	-	5	-	-	-	-	RC1
TA-035-027	3.50	2.70	-	-	-	-	-	M3	M3	-	M5	
TA-036-028	3.55	2.80	M3.5	6	-	-	4	-	-	-	-	
TA-040-032	4.00	3.15	M4	-	5/32"	-	-	-	-	-	-	
TA-045-034	4.50	3.40	-	-	-	-	-	M4	M4	M6	M6	RC2
TA-045-036	4.50	3.55	M4.5	8	-	-	3	-	-	-	-	
TA-050-040	5.00	4.00	M5	10	3/16"	-	2	-	-	-	-	
TA-056-045	5.60	4.50	-	12	7/32"	-	1	-	-	-	-	
TA-060-049	6.00	4.90	-	-	-	-	-	M5,M6	M5,M6	-	-	RC2
TA-060-049	-	-	-	-	-	-	-	M8	-	-	M8	
TA-063-050	6.30	5.00	M6	1/4"	1/4"	-	0	-	-	-	-	
TA-070-055	7.00	5.50	-	-	-	-	-	M10	-	-	M10	
TA-071-056	7.10	5.60	M7	-	-	-	-	-	-	-	-	RC2
TA-080-063	8.00	6.30	M8	5/16"	5/16"	1/8"	-	-	M8	-	-	
TA-080-063	-	-	M11	7/16"	7/16"	-	-	M11	-	M11	M11	
TA-090-071	9.00	7.10	M9,M12	1/2"	1/2"	-	-	M12	M9	M12	M12	
TA-100-080	10.00	8.00	M10	3/8"	3/8"	1/4"	-	-	M10	-	-	

Please ensure that the Range Prefix code precedes the rest of the code number when ordering - e.g. RC2 TA-100-080

• = Standard Product - Normally Ex Stock
 ○ = Standard Product - Availability on Request

Collets

Quick Change Tap Adaptors: Fixed Length - Code RC cont'd

Ordering No.	Shank dia	sqra/f	ISO 529/1982					DIN				Range Prefix			
			metric	unc/unf	bsw/bsf	bsp	ba	352	371	374	376				
TA- 110- 090	11.00	9.00	-	-	-	-	-	M14	-	M14	M14	RC3	RC2		
TA- 112- 090	11.20	9.00	M14	9/16"	9/16"	-	-	-	-	-	-				
TA- 120- 090	12.00	9.00	-	-	-	-	-	M16	-	M16	M16				
TA- 125- 100	12.50	10.00	M16	5/8"	5/8"	-	-	-	-	-	-				
TA- 125- 100BSP	-	-	-	-	-	3/8"	-	-	-	-	-				
TA- 140- 112	14.00	11.20	M18,M20	3/4"	3/4"	-	-	M18	-	M18	M18				
TA- 160- 120	16.00	12.00	-	-	-	-	-	M20	-	M20	M20				
TA- 160- 125	16.00	12.50	M22	7/8"	7/8"	-	-	-	-	-	-				
TA- 160- 125BSP	-	-	-	-	-	1/2"	-	-	-	-	-				
TA- 180- 140	18.00	14.00	M24	1"	1"	-	-	-	-	-	-			RC4	
TA- 180- 140BSP	-	-	-	-	-	5/8"	-	-	-	-	-				
TA- 180- 145	18.00	14.50	-	-	-	-	-	M22,M24	-	M22,M24	M22,M24				
TA- 200- 160	20.00	16.00	M27,M30	1.1/8"	1.1/8"	-	-	M27	-	M27	M27				
TA- 200- 160BSP	-	-	-	-	-	3/4"	-	-	-	-	-				
TA- 220- 180	22.00	18.00	-	-	-	-	-	M30	-	M30	M30				
TA- 220- 180BSP	-	-	-	-	-	7/8"	-	-	-	-	-				
TA- 224- 180	22.40	18.00	M33	1.1/4"	1.1/4"	-	-	-	-	-	-				
TA- 250- 200	25.00	20.00	M36	1.3/8"	1.3/8"	-	-	M33	-	M33	M33				
TA- 250- 200BSP	-	-	-	-	-	1"	-	-	-	-	-				
TA- 280- 220	28.00	22.00	-	-	-	-	-	M36	-	M36	M36				
TA- 280- 224	28.00	22.40	M39,M42	1.1/2"	1.1/2"	-	-	-	-	-	-				
TA- 280- 224BSP	-	-	-	-	-	1.1/8"	-	-	-	-	-				
TA- 315- 250	31.50	25.00	M45,M48	1.3/4"	1.3/4"	-	-	-	-	-	-				
TA- 315- 250BSP	-	-	-	-	-	1.1/4"	-	-	-	-	-				
TA- 320- 240	32.00	24.00	-	-	-	-	-	M39,M42	-	M39,M42	M39,M42				
TA- 355- 280BSP	35.50	28.00	-	-	-	1.1/2"	-	-	-	-	-				
TA- 360- 290	36.00	29.00	-	-	-	-	-	M45,M48	-	M45,M48	M45,M48				

Please ensure that the Range Prefix code precedes the rest of the code number when ordering - e.g. RC2 TA-110-090

• = Standard Product - Normally Ex Stock
 ○ = Standard Product - Availability on Request